

macKLIPS - MK-001

PRODUCT DATA SHEET:

macKLIPS®



PHYSICAL PROPERTIES:

STRAP:

MOULD LENGTH: 192MM

WIDTH (at widest point): 25MM

MAX DEPTH: 3MM

MATERIAL: TPE

COLOUR: RAL 9022/Pantone Cool Grey 7C
RESISTANCE TO FUELS AND OILS: GOOD TO EXCELLENT

COLLAR:

MOULD LENGTH: 7MM

WIDTH (at widest point): 7.5MM

APERTURE: 5.5MM

MATERIAL: ABS

COLOUR: RAL 6018/Pantone 363

RESISTANCE TO FUELS AND OILS: GOOD TO EXCELLENT

SCREW:

LENGTH: 32MM

WIDTH (at widest point): 11MM

MATERIAL: Steel-Carbon

RESISTANCE TO FUELS AND OILS: EXCELLENT

COMBINED PROPERTIES:

PRODUCT CODE: MK-001

STANDARD PACK SIZE: 15 X COMBINED

STRAPS + 15 X DESIGNED SCREWS

COMBINED WEIGHT (strap + collar):

6.55g/set

APROX WEIGHT CARRYING CAPACITY (per fixing) : 2kg

OTHER PROPERTIES (combined):

SERVICE TEMPERATURE RANGE: -30°C to 80°C

TENSILE STRENGTH(Mpa): 6 ± 2

TEAR STRENGTH (kgf/cm²): 40 ± 12

MELT FLOW INDEX (2.16kgs @ 180°C): 6 ± 2

STRAP

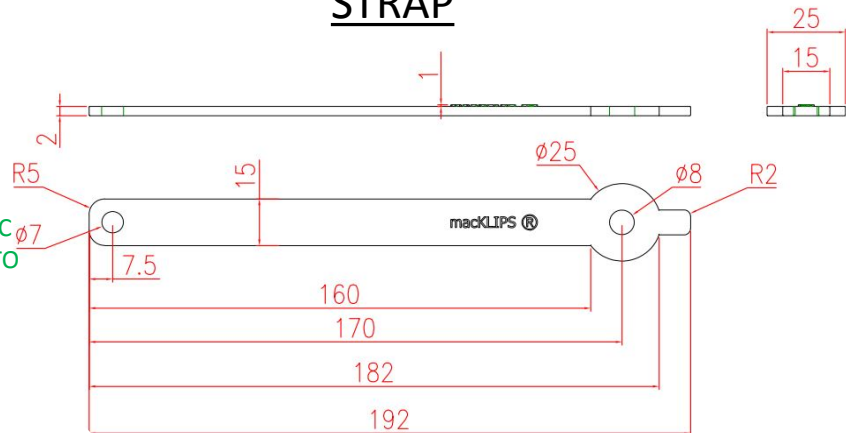

COLLAR

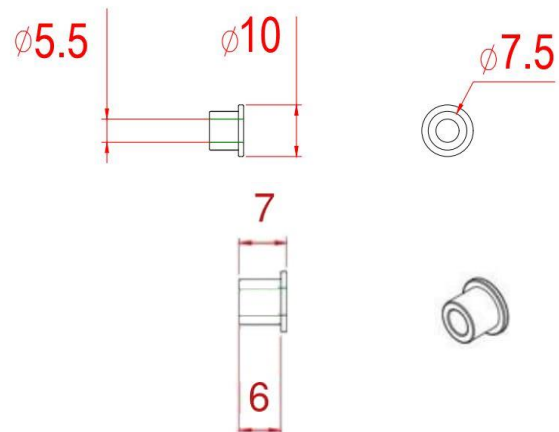

SCREW

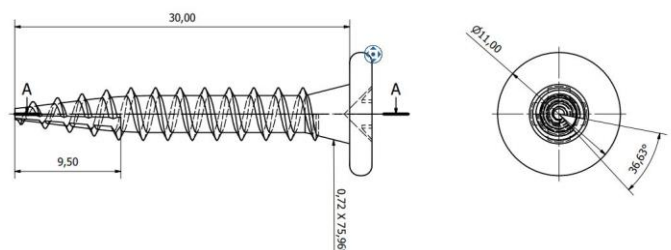

FOR MORE INFORMATION CONTACT INFO@MACKLIPS.COM OR VISIT WWW.MACKLIPS.COM